



RES-FC MARKET

—— Regional markets of RES-fuel cell systems for households ——

Det Radikale Venstre 23-10-2007

Claus Torbensen, WP4 leader
Hydrogen Innovation & Research Centre, Herning

Formål med projektet:

Fremskynde og billiggøre implementeringen af demonstrationsmarkeder i Europa for brændselscelle baserede kraftvarme systemer til husstande der kører på brint produceret fra vedvarende energikilder.

Vind → H₂

Biogas → H₂

Metanol → H₂

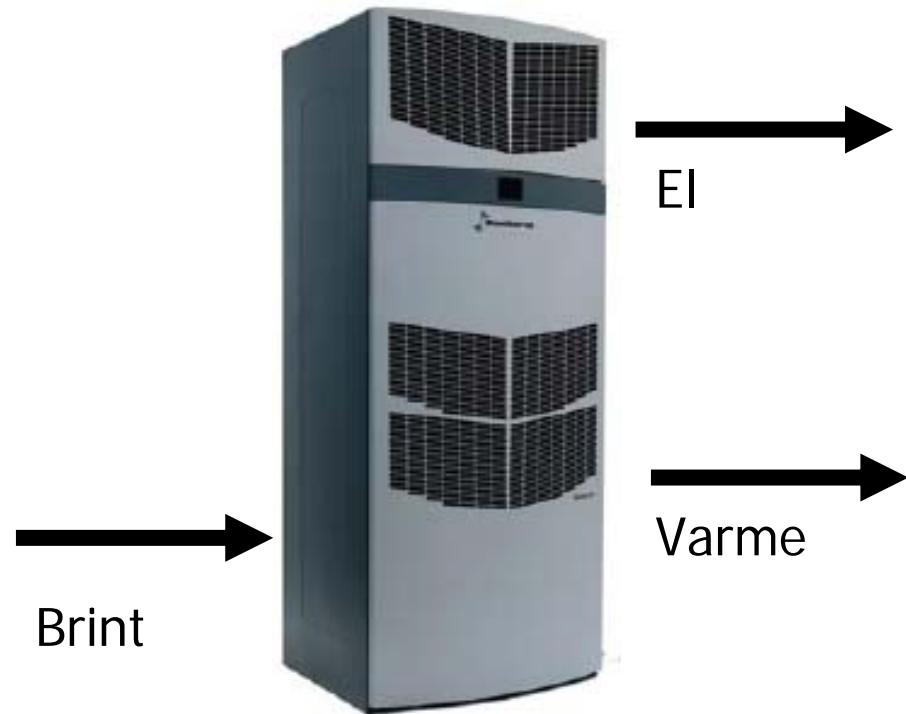

Vind-el til brint til el – hvorfor?

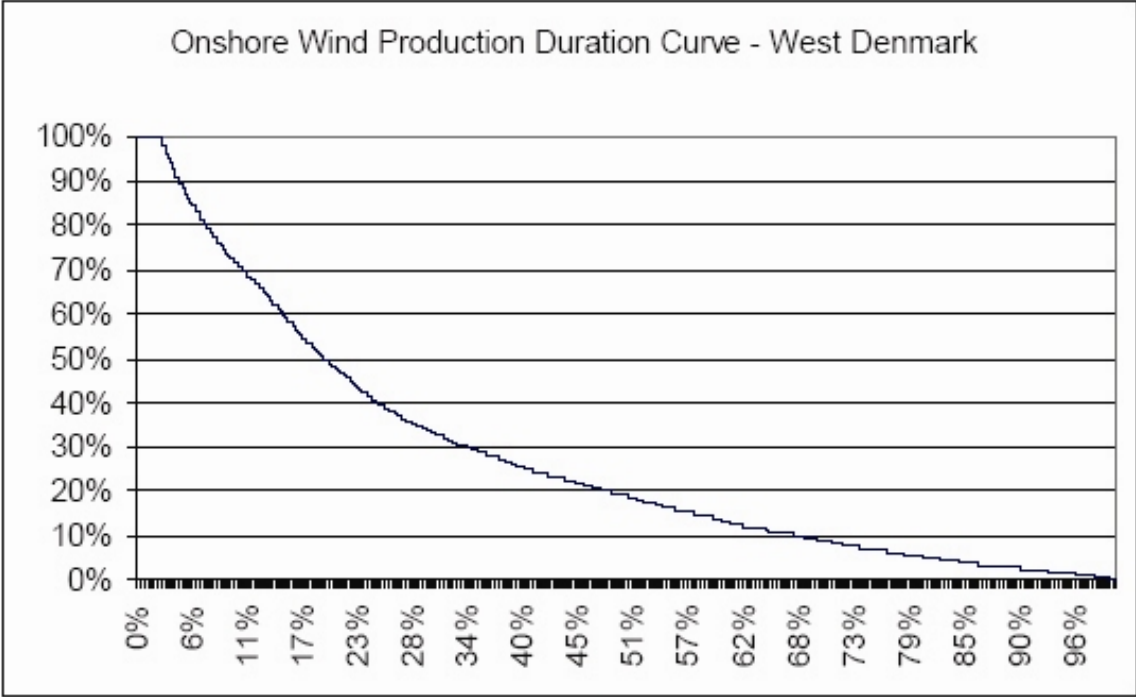

Elproduktion og elforbrug lige nu: 23/10/2007 14:18

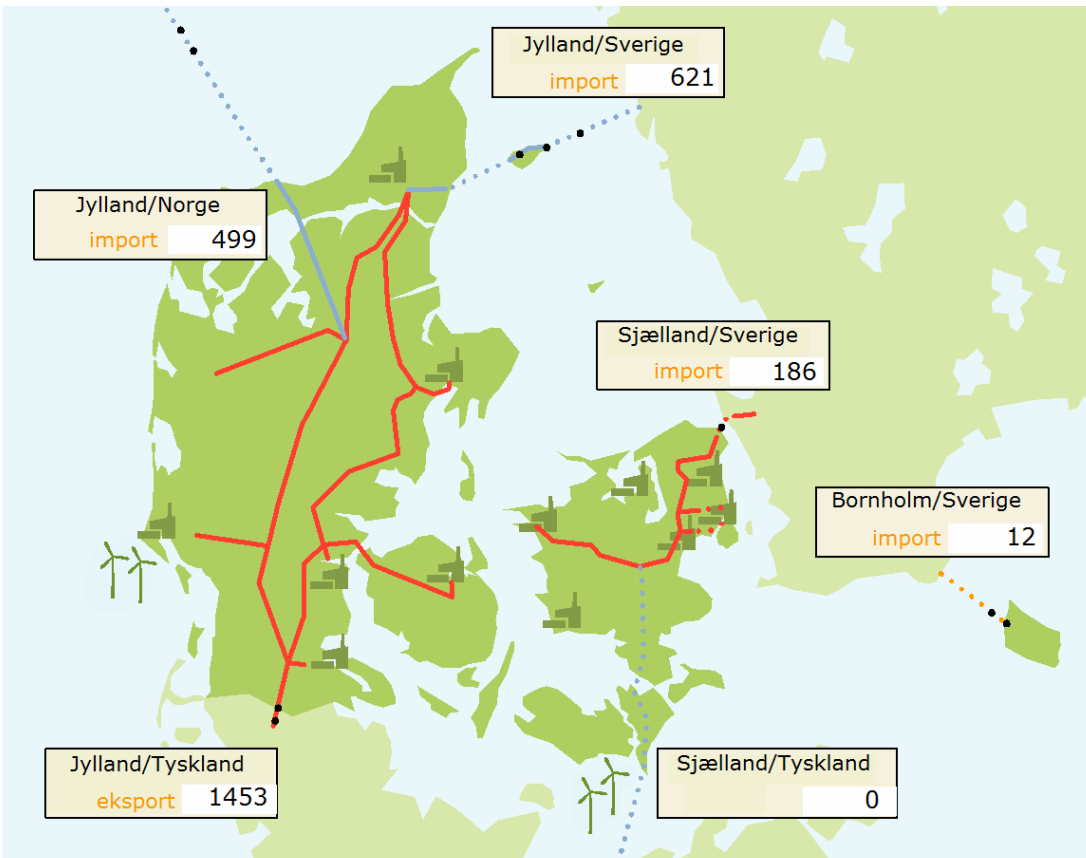







Vestdanmark

Østdanmark

Hele Danmark

Produktion i MW:	
Centrale kraftværker	3768
Decentrale kraftværker	1314
Vindmøller	140
Nettoudveksling	eksport 135
Elforbrug	5087

-  Centralt kraftværk
-  Havmøllepark
-  400 kV luftledning, vekselstrøm
-  400 kV kabel, vekselstrøm
-  Luftledning, jævnstrøm
-  Kabel, jævnstrøm
-  60 kV kabel

Vind-el til brint til el og varme

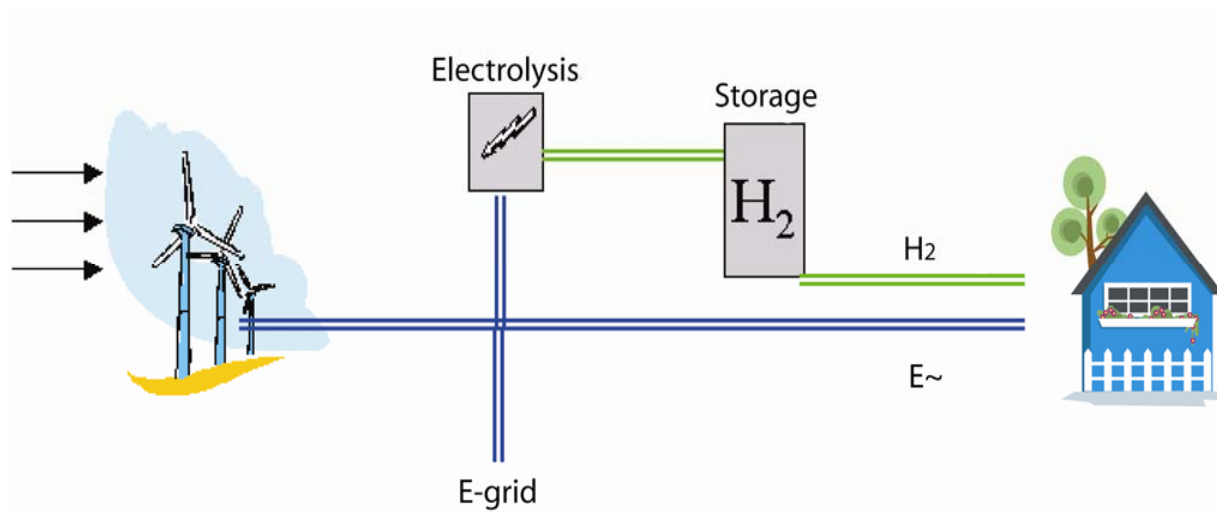

RES-FC MARKET

Primære midler:

- Identificere planlagte og potentielle demonstrationsmarkeder i forskellige europæiske regioner
- Reducere enhedsomkostningerne via standardisering af løsninger på tværs af planlagte projekter og etablere fælles indkøb.



Primære midler:

<i>Regional markets</i>	<i>Performance indicator</i>	<i>Need of RES integration</i>	<i>End-users</i>	<i>Infrastructure</i>	<i>Subsidy</i>
Country	Technology	Technical	2010	H ₂	€/kWh
Iceland	Biomass	no	0	no	
Germany	Excess wind	yes	450	340 km	
Germany	Biogas	no			
Germany	Biomass	no			350 €/ha
Holland	Excess wind	no	300	100 km	0.065
Portugal	Excess wind	yes	10	no	
Spain	Excess wind	yes	20-40	no	
Denmark	Excess wind	yes	400	no	0.013
Denmark	Biogas	no			
Denmark	Biomass	no			350 €/ha

Learning Curve, 1 kW el, Pure Hydrogen, 40.000 Hours Lifetime

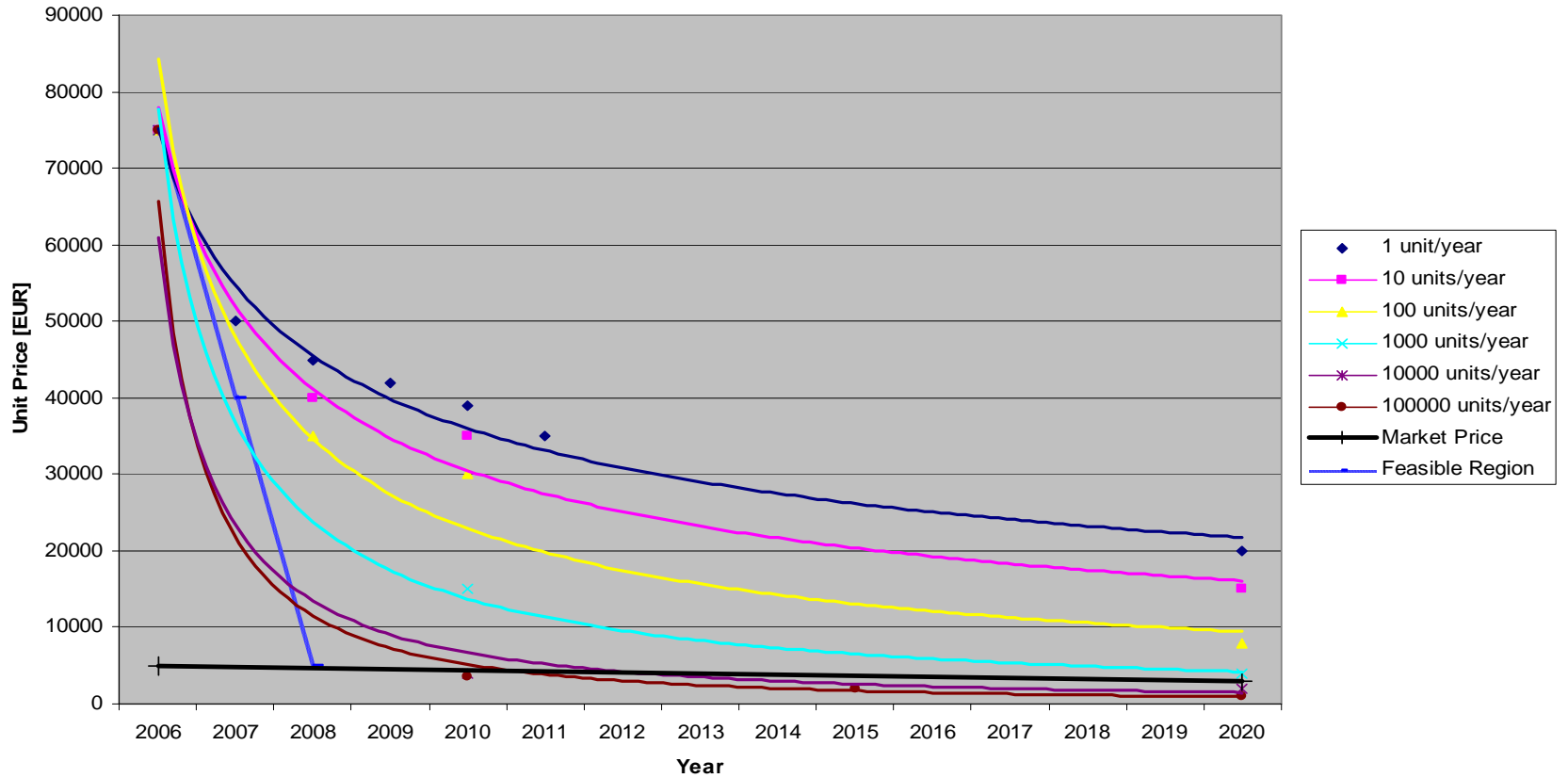

Hvad skal der til for at kommercialisere denne teknologi?

Kort sigt/demonstrationsfase:

Offentlige støttekroner til demonstrationsprojekter

Middel sigt/markedsintroduktion:

- Subsidie ordninger
- Klar og gennemskuelig lovgivning på området

